	Methodology	Department:	System Planning
		Document No:	PLG-METH-0002-V22.3
Title: Transmission Planning Assessment Practices		Issue Date:	March 14, 2024
		Previous Date:	March 14, 2023

SCOPE

This document is part of the ATC system Planning Criteria. These criteria define system performance requirements. Consideration is given to ensure a safe and reliable transmission system. These methodologies address customer expectations and compliance with NERC standards. These methodologies apply to the ATC transmission system operated at 69-kV and above, except as otherwise noted.

This document may be revised from time to time in response to changes in industry standards, new system conditions, new technologies and new operating procedures, as appropriate. The criteria described below will be subject to change at any time at ATC's discretion. Situations that could precipitate such a change could include, but are not limited to, new system conditions, extraordinary events, safety issues, operation issues, maintenance issues, customer requests, regulatory requirements and Regional Entity or NERC requirements.

Approved By:	Prepared By: Damien Sommer, Chengyue Guo, et alia
---------------------	----------------------------------------------------------

Transmission Planning Assessment Practices

- 1. Introduction 4
- 2. Capacity Benefit Margin Methodology 6
- 3. Transmission Reliability Margin Methodology 7
- 4. Facility Rating Methodology..... 7
 - 4.1. Equipment Thermal Loadability Ratings..... 7
 - 4.2. Voltage Ratings 8
- 5. Model Building Methodology..... 8
 - 5.1. Voltage Schedule..... 8
 - 5.2. Generation Dispatch..... 9
 - 5.3. Net Scheduled Interchange 10
 - 5.4. Dynamic Load Modeling 10
- 6. Facility Condition Methodology..... 11
- 7. Planning Zones 12
- 8. System Alternatives 12
- 9. Load Forecasting Methodology 12
 - 9.1. Summer Peak 13
 - 9.2. Shoulder maintenance window..... 13
 - 9.3. Winter Peak 13
 - 9.4. Fall/spring Off-Peak 13
 - 9.5. Summer 90/10 Peak..... 13
 - 9.6. Light Load (50 Percent of Summer Peak)..... 14
 - 9.7. Minimum Load (40 Percent of Summer Peak) 14
- 10. Economic Methodology..... 14
- 11. Environmental Methodology 15
- 12. Other Considerations 15
 - 12.1. Project Constructability 15
 - 12.2. Multiple Contingency Planning 16
 - 12.3. Substation Bus and Terminal Equipment Limitations..... 16
 - 12.4. Maximization Use of Existing Rights-of-Way..... 16
 - 12.5. Reduction of Transmission System Losses 17
 - 12.6. Transmission System Operating Considerations in the Planning Process 17
 - 12.7. Radial Transmission Service 17
 - 12.8. Relaxation of Criteria 18
 - 12.9. Steady State Voltage Stability Margin Identification..... 18
 - 12.10. Series Reactor Application Project Diagram 19
 - 12.11. Non-BES Generating Unit Stability..... 19
- 13. Interconnection Studies 19

Caution: Any hard copy reproductions of this document should be verified against the on-line system for current revisions.

Transmission Planning Assessment Practices

- 13.1. Types of Analysis..... 19
- 13.2. Compliance with Applicable Requirements 20
- 13.3. Coordination with Affected Entities..... 20
- 13.4. Essential Documentation 20
- 13.5. Flow Regulating Equipment..... 20
- 13.6. Specific Study Methodologies 20
- 13.7. Other ATC Interconnection Studies and Considerations 21
- 13.8. Generator Material Modification Study Review Prior to Commercial Operation 22
- 14. Under-Frequency Load Shedding (UFLS)..... 22
- 15. References..... 23
- 16. Administration 23
 - 16.1. Review 23
 - 16.2. Retention 23
- 17. Revision History 24

1. INTRODUCTION

American Transmission Company (ATC) generally subscribes to the zone approach to transmission planning assessment using a multi-level planning concept. Diagrams of the planning zones for which regional plans have been developed by ATC are attached in the response to Part 3 of Federal Energy Regulatory Commission (FERC) Form 715 and show the existing transmission facilities, 100-kV and above, within ATC's transmission system.

The concept behind the zone approach to transmission planning is to develop plans that consider all the needs, limitations, and developments within each zone and develop an overall plan for the zone (that is, a plan that emphasizes projects that serve multiple purposes or solve multiple limitations within the zone). In addition, ATC's transmission planning philosophies incorporate the concept of multi-level transmission planning. When carrying out a comprehensive transmission planning process, consideration must be given not only to transmission needs, zone needs, and ATC-wide needs, but also to plans of other transmission providers. Solutions identified via planning activities within each level are vetted against those in adjacent levels until the most effective overall comprehensive plan is developed. ATC's planning process will continue to develop the first three levels (individual, zone, ATC-wide). ATC is participating with other Transmission Owners, such as ComEd, DPC, MP, NSP, and ITC, within and affected by MISO territory in assessing regional needs.

ATC employs the long-standing practice of using power flow analysis to identify needs and limitations and to evaluate alternative mitigation measures. ATC identifies limitations and needs by simulating non-simultaneous and selected simultaneous outages of each line, transformer, bus section, and generator. ATC does implement operating guides, such as opening lines and bus sections, to mitigate limitations (overloads, low voltages, etc.) during extreme flow conditions.

ATC also conducts dynamic stability analyses within each of its zones to assess the ability of its system to withstand power system disturbances. Many of these analyses have been or are being conducted in conjunction with proposed generation interconnections. Other independent analyses are being conducted to assess dynamic and/or voltage stability performance.

ATC performs Electromagnetic Transient (EMT) simulations in certain situations or scenarios involving inverter-based resources (IBRs). These include, but are not limited to, interaction with other neighboring IBRs, low short-circuit strength pockets, or other sub-synchronous or super-synchronous controls issues.

ATC develops transmission projects to address the congestion issues in its system and beyond. ATC uses the PROMOD model to analyze congestion across the ATC system and surrounding systems and develops projects that will relieve the congestion.

Further, ATC works with neighboring transmission owners, stakeholders and MISO to develop transmission projects that provide multiple benefits including reliability, economic and public policy benefits. These projects are often more strategic and regional in nature to

help provide benefit to multiple areas as well as maintain reliability in the ATC system well into the future. These projects are evaluated using traditional reliability planning tools, PROMOD for economic benefits and a combination of traditional first contingency incremental transfer capability (FCITC) analysis and economic analysis to quantify their public policy benefits.

As part of MISO, ATC participates in the MISO Transmission Expansion Planning (MTEP) process. ATC participates actively in portions of MISO's planning efforts, including committees and task forces, in regional and economic study efforts and in development of the MTEP.

ATC solicits public and other stakeholder input on the identification of ultimate solutions through its iterative planning process. Projects may be modified as potential solutions listed in this plan and are further developed to address the specific needs identified by all stakeholders. The solutions selected to address the needs and limitations identified will reflect the input of transmission planning process stakeholders, including customers, state and local officials, the public, and coordination with other planning processes, to the extent possible.

Specific opportunities for public and stakeholder participation in the planning process are provided in accordance with ATC's tariff Attachment FF filed at FERC in response to the portion of FERC's Order 890 and 1000 calling for open, inclusive, and transparent planning processes. The order was approved conditionally and, after a compliance filing by ATC, it was approved in August 2010. ATC's Attachment FF covers planning processes and functions including opportunities for stakeholders to participate in the processes. The planning processes and functions include:

- 1) Network adequacy planning
- 2) Economic project planning
- 3) Generation-transmission interconnections
- 4) Transmission-distribution interconnections
- 5) Transmission-transmission interconnections
- 6) Transmission service requests
- 7) Public policy

Provisions include opportunities for stakeholders to provide input to the planning processes in terms of assumptions and projects, providing review of interim results and examination of final results.

ATC participates in regional transmission assessments conducted by the RF Transmission Performance Subcommittee (TPS), the Eastern Interconnection Reliability Assessment Group (ERAG) Reliability Assessments and MISO Reliability Assessments.

In addition to the planning criteria, ATC considers many other factors in its transmission planning process. The following is a description of such factors.

2. CAPACITY BENEFIT MARGIN METHODOLOGY

Capacity Benefit Margin (CBM) is the amount of firm transmission transfer capability preserved to enable access by Load Serving Entities (LSEs) to generation from interconnected systems to meet generation reliability requirements, such as meeting firm load obligations during a capacity emergency. Preservation of CBM for an LSE allows that entity to reduce its installed generating capacity below that which may otherwise have been necessary without interconnections to meet its generation reliability requirements. The transmission transfer capability preserved as CBM is intended to be used by the LSE only in times of emergency generation deficiencies.

As in MISO planning studies, ATC planning studies (other than the flow-based analysis required for MISO transmission service studies) will not model CBM. CBM is instead accommodated by ensuring that local resource zones (LRZs) have the necessary emergency import capability through Loss of Load Expectation (LOLE) studies performed by MISO and governed by the obligations of the MISO Module E of Energy Markets Tariff. If a deficiency is identified, any resulting incremental import capability requirements will be incorporated into ATC's overall transmission expansion plan.

MISO performs annual LOLE studies to determine the installed planning reserve margin that would result in the MISO system experiencing one loss of load event every ten years on average. This equates to a yearly LOLE value of 0.1 days per year. This value is determined through analysis using the Strategic Energy & Risk Valuation Model (SERVM) software, managed by Astrapé Consulting. PROMOD software is used to perform a security constrained economic dispatch analysis which determines congestion related LRZs which are used in the SERVM modeling. This analysis occurs on an annual basis to determine the LRZs and planning reserve margin for the next planning year as well as two other analysis years in the ten-year horizon.

As part of the LOLE studies, MISO calculates the Generation Capability Import Requirement (GCIR) for each LRZ. An import level equal to the GCIR level for each LRZ is simulated, and the MW impacts on each defined flowgate are recorded. For each flowgate, the highest MW impact due to a GCIR import into a LRZ becomes the calculated CBM for that flowgate.

Then, for each flowgate MISO compares the flowgates calculated CBM to the Automatic Reserve Sharing (ARS) component of the Transmission Reliability Margin (TRM) for that same flowgate. Since the worst-case loss of a single resource is already covered by the ARS component of TRM, this amount of capacity is not redundantly preserved as part of CBM. If the ARS component is greater than the calculated CBM, no CBM will be preserved

on that flowgate. If the ARS component is less than the calculated CBM, the incremental amount of CBM that is needed above the ARS component will be preserved as CBM for that flowgate.

3. TRANSMISSION RELIABILITY MARGIN METHODOLOGY

TRM is the amount of transmission transfer capability necessary to provide reasonable assurance that the interconnected transmission network will be secure during changing system conditions, particularly during Reserve Sharing events such as the loss of a critical single unit. TRM accounts for the inherent uncertainty in system conditions and the need for operating flexibility to ensure reliable system operation as system conditions change.

In the planning horizon, anytime beyond 48 hours, MISO uses reservations from other transmission providers and Balancing Authority generation dispatch to reduce uncertainty. MISO will apply a two percent reduction in normal and emergency ratings for input uncertainties in the planning horizon. This is often referred to as the uncertainty component of the TRM.

The ARS component of TRM is the amount of transmission transfer capability required on a flowgate to deliver Contingency reserves. These Contingency reserves are defined as 100 percent of the impact of the greatest single Contingency impacting the flowgate. The worst single Contingency is determined by tripping units (or transmission elements) within the region and replacing the lost resource with a realistic dispatch for each reserve sharing member's share of the emergency energy. The worst case is the case that has the greatest incremental flow across the flowgate. The highest incremental flow on the flowgate for the Contingencies evaluated (generation and transmission) will be the amount of ARS TRM required.

MISO uses the summation of the ARS and two percent uncertainty components of TRM in the network analysis for Long-Term Transmission Service Requests. Please reference the MISO Transmission Reliability Margin Identification (TRMID) methodology for a description of the application of TRM to all Transmission Service Requests.

4. FACILITY RATING METHODOLOGY

4.1. Equipment Thermal Loadability Ratings

ATC maintains criteria to establish ratings for substation equipment, overhead transmission lines and underground transmission lines for use in planning and operating the ATC network. These criteria are applied to all components and elements of the ATC network and facility ratings are determined and managed in the Substation Equipment and Line Database (SELD) application. Procedures are in place to govern the application of those criteria and the process for updating the facility ratings database for modifications to existing facilities and the addition of new facilities.

(Applicable NERC Standards: Current Version of FAC-008-R3)

4.2. Voltage Ratings

The standard voltage percentage ratings (limits) of being within 95% to 105% of nominal system voltage for normal conditions and within 90% to 110% of nominal system voltage for emergency condition will be applied, except when special voltage limits are observed. Special voltage level limits are those acceptable to the affected transmission customers or needed to address specific ATC equipment limitations. Special voltage level limits, derived from a list maintained by ATC, are reflected in the PSSE models, incorporated into the standard PSSE voltage monitor file and available for application in other analytical tools.

5. MODEL BUILDING METHODOLOGY

ATC will strive to develop and maintain consistency in the power flow models used for planning efforts and in assessing whether and under what conditions transmission service is available. The starting point for ATC power flow models will be MMWG models. ATC will use load forecasts provided by the company's end-use load-serving customers as input into future model building efforts, both internally and in conjunction with NERC, Regional Entity (RE), and Regional Transmission Organization (RTO) initiatives. These forecasts may be adjusted by ATC if adjustments are needed for transmission planning purposes either with concurrence from the company's customers or independently of the company's customers. All ATC power flow models will be developed using PTI PSS/E software.

Further details can be found at the Ten-Year Assessment (TYA) Website (www.atc10yearplan.com), "Planning methodology and assumptions".

(Applicable NERC Standards: Current Version of MOD-032)

5.1. Voltage Schedule

- 1) The power flow models will implement ATC's generator voltage schedule. The generator voltage schedule is defined as a:
 - a. Target voltage of 102 percent of the nominal transmission voltage as measured at the point of interconnection between the generator and the transmission network unless another voltage schedule has been identified.
 - b. Normal voltage range of 95 to 105 percent of nominal transmission voltage.

Due to limitations imposed by the NERC model building process, the generator voltage schedule target modeled in the NERC power flow models may only approximate ATC's voltage schedule at the point of interconnection.

(Applicable NERC Standard: Current Version of VAR-001)

- 2) Generators that do not have automatic voltage regulation (AVR) or are not controllable (unmanned stations and no remote control) have been considered. When modeling these generators, special attention must be given to the limitations of these units.

5.2. Generation Dispatch

5.2.1. General Dispatch Methodology

- 1) Generation reported by ATC's members will be dispatched in accordance with contractual and local or regional economic dispatch considerations, as applicable.
- 2) Voltage and Local Reliability (VLR) units identified in a MISO standing Operating Guide will be dispatched out of merit order, in accordance with the standing Operating Guide.
- 3) Generator Interconnection studies follow the dispatch guidelines defined in Section 13.6.1.

5.2.2. Distribution Connected Generation

Distribution connected generation (DCG) will be modeled according to the "ATC Generator Modeling Decision Methodology"¹ which is accessible on ATC's external website.

5.2.3. Wind Generation Dispatch Methodology

- 1) Generator Interconnection studies will model wind generation following the guidelines in the MISO Business Practice Manual for Generator Interconnections.
- 2) TYA studies will model wind generation following the MISO methodology of applying the MISO capacity credit value for peak (typically 14-16%) and 40% off-peak, although sensitivity analyses may dispatch wind generators at various output levels.

5.2.4. Solar Generation Dispatch Methodology

- 1) Generator Interconnection studies will model solar generation following the guidelines in the MISO Business Practice Manual for Generator Interconnections.
- 2) TYA studies will model solar generation following the MISO methodology of applying the MISO capacity credit value for peak (typically ~50%) and 31% off-peak, although sensitivity analyses may dispatch solar generators at various output levels.

5.2.5. Hydro Generation Dispatch Methodology:

- 1) The summer peak P_{max} dispatch levels have been reflected in the powerflow model's unit P_{max} capability. In some instances, P_{max} may not be equal to rated power.
- 2) If documented typical summer peak dispatch information is available it may be used, provided it does not exceed the latest available Generator Owner's MOD-025 test data.

¹ Revision 1.0 of the guide is available for download at www.atcllc.com

- 3) If documented typical summer peak dispatch information is not available, then a default dispatch of 30 percent² of unit rated power will be applied. If the 30 percent of unit rated power value exceeds the MOD-025 test data then the unit will be dispatched to the P_{max} derived from the Generator Owner's MOD-025 test data. If the 30 percent of unit rated power value is less than the MOD-032 P_{min} data for the unit, the unit will be dispatched to its P_{min} value.
- 4) Studies for fall, winter and spring may use different assumptions.

5.3. Net Scheduled Interchange

- 1) Net scheduled interchange for the ATC system will be coordinated with the necessary regional and interregional parties.
- 2) Net scheduled interchange for the ATC system may be altered to evaluate realistic system conditions of significance for system planning purposes.

5.4. Dynamic Load Modeling

- 1) The composite load model is presently considered the industry standard in dynamic load modeling, enabling representation of three phase and single-phase induction motors, power electronic load, static load, distributed generation, and the distribution equivalent network. It also allows for modeling of the protection systems around each component, which is useful for representing end-use load dropping due to system conditions. The composite load model is implemented in commonly used software platforms such as GE PSLF, PTI PSS®E, PowerWorld, and DSATools.
- 2) Figure 5.4.1 below shows the overall structure of the composite load model; the major components of the model include:
 - a. Definition of load composition
 - b. Substation transformer (LTC) and distribution feeder equivalent impedance
 - c. Substation and distributed feeder shunt compensation
 - d. 3-phase motor loads with built-in protection
 - e. 1-phase motor loads with built-in protection
 - f. Power electronic loads
 - g. Static representation of loads

² 30 percent of rated power was determined to be a typical hydro generation dispatch level based on internal review of hydro generation dispatch levels over four years (2008–2012) as documented in ATC's PI Historian data.

- h. Load shedding – UFLS, UVLS
 - i. Distributed generation resources
- 3) The NERC Load Model Data Tool (LMDT) developed for industry use uses a spreadsheet for data management that includes defined zones for loads to compensate for geographic variations in load types
 - 4) LMDT uses Python and MATLAB scripts to write PSS®E DYR data records that are submitted to MISO on an annual basis per the MISO Reliability Planning Model Data Requirements & Reporting Procedures. These submissions are based on load modeling data provided by Clear Springs Energy.

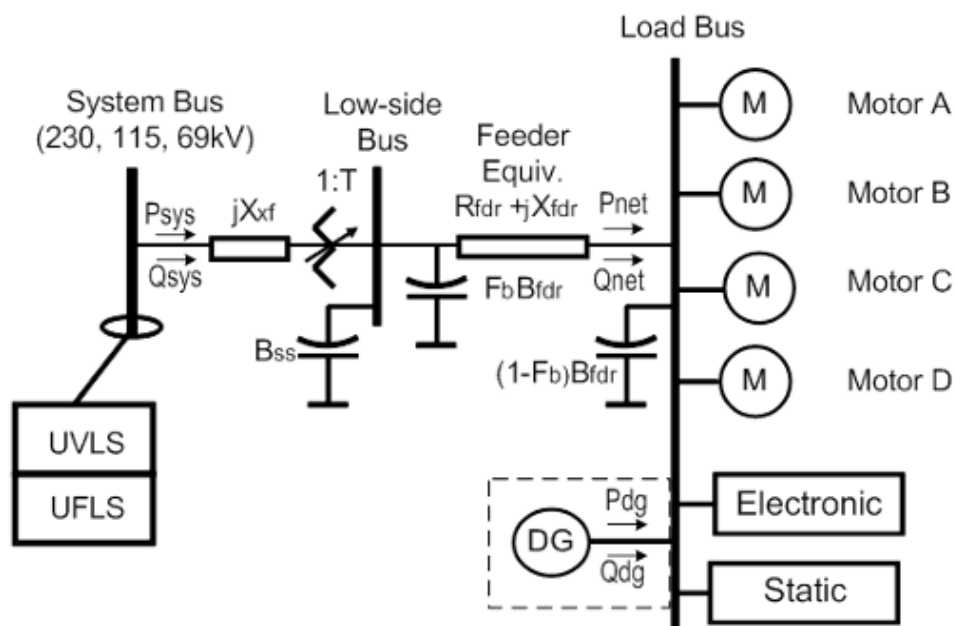

Figure 5.4.1: Composite Load Model Structure (CMPLDW/CMLD)
 REF: NERC Dynamic Load Modeling Technical Reference Document, December 2016

6. FACILITY CONDITION METHODOLOGY

The objective of ATC's asset renewal program is to ensure that assets perform the required function in a sustainable manner while managing life-cycle costs. Replacement of equipment is done in coordination with network planning and other functional groups and stakeholders to ensure replacement equipment is warranted and meets future needs.

ATC's asset management program is driven by safety, compliance, and reliability performance. Additionally, known equipment problems are tracked and upgrades implemented as part of the asset renewal program. Through asset maintenance and

inspection programs, staff monitor the system to identify issues related to performance or condition.

Some equipment may be replaced due to technological enhancements that improve the performance of the transmission system. In the case of protective relays, as an example, the newer devices provide better event data that can speed restoration after outages. Coordination will occur with the replacement of other equipment to take advantage of cost synergies that result in an overall lower cost and impact to the transmission system.

7. PLANNING ZONES

ATC will conduct system planning on a long-range basis by developing plans for the ATC transmission system, as well as plans for specified zones within the boundaries of ATC's transmission system. The idea behind the zone approach to long-range planning is to develop plans that consider all the needs/problems/developments within each zone. The goal within the ATC system is to develop an "umbrella" plan for each zone, that is, a plan that emphasizes projects that serve multiple purposes or solve multiple problems within the ATC system. The zone approach is intended to address requirements for support to the local distribution systems in that zone on a least cost basis. It is anticipated, however, that several projects that span more than one zone or possibly even the ATC transmission system boundaries may evolve. Such projects will likely involve coordination with other transmission owners or regional transmission organizations.

The planning zones deviate significantly from existing control area boundaries and from planning zones traditionally used for joint planning in conjunction with the Wisconsin PSC. The zones were selected considering the need for a manageable number of planning areas and to consolidate areas within the state with similar topology and load characteristics.

8. SYSTEM ALTERNATIVES

ATC may consider alternatives to transmission solutions to problems on the transmission system, if needed. Such alternatives could include, but are not limited to, central station generation, distributed generation, load management and conservation measures. ATC will use sound judgment in assessing whether non-transmission solutions are applicable on a case-by-case basis, keeping in mind that ATC is not a vertically integrated utility and does not own generation or serve as a load serving entity for retail load.

9. LOAD FORECASTING METHODOLOGY

ATC will initially use load forecasts provided by the company's end-use load-serving customers. In general, customers are required, to provide ATC with monthly peak demand forecasts for the next 11 years. ATC may, in the future, develop load forecasts either concurrent with or independent of the company's load-serving customers. In addition, ATC may, in coordination with the company's load-serving customers, develop representative load duration curves based on actual and normalized load conditions.

In utilizing or developing load forecasts, the following methodology will be used:

9.1. Summer Peak

Summer peak demand forecasts will be calculated in such a way that there is an almost equal probability of exceeding or falling short of the forecast when average peak making weather does occur.

9.2. Shoulder maintenance window

To develop a shoulder maintenance window model, a maintenance window analysis should be performed for the ATC system periodically. This analysis should determine:

- 1) The number of load pockets the ATC system should be divided into.
- 2) The overall load level, in terms of a percentage of the summer peak, to be achieved for each load pocket.

Then for each load pocket, the shoulder maintenance window forecasts will be developed such that the scalable loads are scaled to a pre-calculated percent of the summer peak demand forecasts while holding the non-scalable loads smaller than or equal to 5 MW constant and applying shoulder load ratios³ for the non-scalable loads greater than 5 MW. The resultant overall load level should meet the target determined in the latest maintenance window analysis. The ratio of the real to reactive power of the loads will remain unchanged from the summer peak ratio.

9.3. Winter Peak

Winter peak demand forecasts will be developed such that the scalable summer peak loads are scaled to Local Distribution Company (LDC) chosen percentages for the following December. Non-scalable loads remain unchanged. The ratio of the real to reactive power of the loads will remain unchanged from the summer peak ratio.

9.4. Fall/spring Off-Peak

Fall/spring off-peak demand forecasts will be developed such that the scalable loads are scaled to LDC chosen percentages for the month of November for fall or the month of April for spring. Non-scalable loads smaller than or equal to 5 MW remain unchanged while applying shoulder load ratios³ for the non-scalable loads greater than 5 MW. The ratio of the real to reactive power of the loads will remain unchanged from the summer peak ratio.

9.5. Summer 90/10 Peak

Summer 90/10 peak demand forecasts will be developed that reflect above-average summer weather and peak demand conditions. A true summer 90/10 forecast at the ATC aggregate load level will be developed in such a way that there is a 90 percent probability of falling short of and a 10 percent probability of exceeding the forecast due to weather conditions. Summer 90/10 peak demand forecast will then be developed such that the

³ To enhance the modeling of shoulder and light load conditions for the ATC Planning analysis, during the load forecast process, ATC requested local distribution companies to provide shoulder-to-peak ratios and light-to-peak ratios for the non-scalable loads greater than 5 MW.

scalable loads are scaled to a pre-calculated percent of the summer peak demand forecasts while leaving the non-scalable loads unchanged. The resultant overall ATC load level should meet the determined 90/10 forecast. The ratio of the real to reactive power of the loads will remain unchanged from the summer peak ratio.

9.6. Light Load (50 Percent of Summer Peak)

Light load (50 percent of summer peak) demand forecasts will be developed such that the conforming loads are scaled to a pre-calculated percent of the summer peak demand forecasts while holding the non-scalable loads smaller than or equal to 5 MW constant and applying light load ratios³ for the non-scalable loads greater than 5 MW. The resultant overall ATC load in the Light load model is approximately 50 percent of the summer peak. The ratio of the real to reactive power of the loads will remain unchanged from the summer peak ratio.

9.7. Minimum Load (40 Percent of Summer Peak)

Minimum load (40 percent of summer peak) demand forecasts will be developed in two steps:

- 1) The scalable loads are scaled to a pre-calculated percent of the summer peak demand forecasts, while holding constant the non-scalable loads smaller than or equal to 5 MW constant and applying light load ratios³ for the non-scalable loads greater than 5 MW. The resultant overall ATC load in the Minimum load model is approximately 40 percent of the summer peak.
- 2) Historical EMS model data are used to help developing the reactive load forecast in the minimum load models.
 - a. Obtain the historical (Easter Sunday 4:00 AM and Memorial Day 6:00 AM) ATC control area reactive load data for at least three years from EMS models and average them to get the reactive load target for each control area.
 - b. For each of the ATC control areas, the scalable reactive loads are scaled to a pre-calculated level of the summer peak demand forecasts, while holding the non-scalable loads smaller than or equal to 5 MW constant and applying light load ratios³ for the non-scalable loads greater than 5 MW. The resultant overall reactive loads for each control area should meet the target determined in the step above.

10. ECONOMIC METHODOLOGY

ATC will conduct appropriate economic analyses when evaluating transmission additions, replacements, and modifications. The criteria to be used in such economic analyses for purposes of system planning will include the following:

- 1) In developing screening level capital cost estimates for transmission lines and substations, terrain, geology, and land use will be considered.

- 2) In conducting the economic analysis of changes in transmission system losses, hourly line flow data and associated area Locational Marginal Prices (LMPs) for the entire analysis year from PROMOD will be used to analyze the potential savings from reduced transmission line losses associated with a new project (or package of projects).
- 3) The reduction in the need to build additional generation to serve the peak load will be calculated by comparing the losses from the power flows for the peak load hour with and without the project. To correctly do the accounting, the reduction in the generation needed to serve the peak load will be increased by the MISO planning reserve margin. The dollar value of this savings will be based on the construction cost of a combustion turbine.
- 4) The LMP market simulation tool, PROMOD, will be the primary tool used to analyze the economics of projects in the energy market. ATC's Customer Benefit Metric will typically be used to analyze the energy market savings of projects. Generally, PROMOD will be run with and without the project, or package of projects, to determine the energy market savings. Other energy market economic benefits may also be calculated, such as the "insurance benefit" associated with having a more robust transmission grid to respond to low probability, but high impact transmission and generation outages, which can cause energy market prices and costs to spike.

All transmission projects have both reliability and energy market economic impacts. In certain cases, energy market economic benefits may be the primary driver of a project. In addition, energy market economic analysis of projects may be used in the prioritization and staging of projects. In this effort, an attempt is made to capture all relevant factors in determining the energy market economic benefits of a project. Stakeholder input is utilized by ATC for this purpose. Various tools are also utilized by ATC, including the PROMOD software; however, other methods and tools are open to consideration.

11. ENVIRONMENTAL METHODOLOGY

The overriding environmental criterion to be used by ATC in system planning is that environmental analyses will be conducted at a screening level as opposed to a detailed siting/routing analysis level. The goal of such environmental analyses is to identify potential environmental impacts and avoid such impacts where possible. Where it is not possible to avoid such impacts, ATC will minimize and mitigate such impacts to the extent possible. More detailed analyses will be undertaken to support an application to siting authorities of specific transmission alternatives.

12. OTHER CONSIDERATIONS

12.1. Project Constructability

ATC will consider the constructability of proposed additions, replacements, or modifications to the transmission system as part of the company's system planning process. ATC will consider:

- 1) Whether addition, replacement or modification of a transmission line, transformer or other facility would result in violation of the System Performance Criteria.
- 2) Whether addition, replacement or modification of a transmission line, transformer or other facility precludes the ability of ATC Operations to conduct maintenance activities on other transmission facilities.

12.2. Multiple Contingency Planning

There may be circumstances, where the risk to ATC and/or ATC customers of a multiple Contingency event is sufficiently severe to warrant consideration for planning purposes. A multiple Contingency arising from a common cause, such as a fire, flood, lightning etc., and/or a highly probable multiple Contingency based on historical observance where studies indicate that there is potential for Adverse Reliability Impact.

ATC will consider the relative probability and consequences of certain selected multiple Contingency scenarios to determine whether to apply a multiple Contingency standard.

Such multiple Contingency scenarios may warrant consideration of operating guides or reinforcements. In these circumstances, ATC will document the potential event(s), the associated risks and potential mitigation measures, and will coordinate with affected customers, as appropriate.

(Applicable NERC Standard: Current Version of TPL-001)

12.3. Substation Bus and Terminal Equipment Limitations

The following substation bus and terminal equipment rating design methodology would apply to new transmission facilities and should be reviewed when proposing modifications to existing facilities.

- Substation terminal equipment should not be a limiting component of transmission line section and transformer section ratings in all seasons for a P0 event, a P1 event or a maintenance event of a single bus tie breaker.
- In addition, bus sections should be designed such that, under reasonable system configuration scenarios, they are robust enough not to be limiters to any accumulated flows from transmission facilities and generation.

12.4. Maximization Use of Existing Rights-of-Way

ATC will attempt to maximize use of existing rights-of-ways. Existing electric transmission, gas pipeline, railroad and highway corridors will be identified in all comparisons of alternatives and utilized where feasible. Environmental features of a right-of-way are also important to ATC operations. Environmental assessments are built into planning at a high level and are continued into project assessments as projects move forward through to construction. In addition to avoiding and protecting environmentally sensitive areas, ATC is committed to working in partnership with regulators, environmental organizations and landowners to enhance areas of environmental significance.

12.5. Reduction of Transmission System Losses

ATC considers the benefit of reducing system losses along with other performance benefits and cost factors in evaluations of alternative transmission projects or plans. See Section 10, Economic Methodology.

12.6. Transmission System Operating Considerations in the Planning Process

12.6.1. Operating Guides

Operating guides are not preferred under normal conditions, but may be employed by ATC and/or entities with generation and/or distribution facilities interconnected with the ATC transmission system to avoid transmission facility loadings more than normal and emergency ratings provided such guides are practical for sustained periods, if they meet the following conditions:

- 1) Do not compromise personnel or public safety.
- 2) Do not degrade system reliability.
- 3) Do not result in a significant loss of equipment life or significant risk of damage to a transmission facility.
- 4) Do not unduly burden any entity financially.
- 5) Supervisory switching capability is available to accomplish these operating guides. Field switching will not be relied upon to reduce facility loadings or to restore voltages to within acceptable levels.
- 6) ATC will strive to verify the efficacy of all operating guides that require on-site operations.

12.6.2. Operational Flexibility

ATC's System Planning will strive to plan the transmission system such that operating flexibility is maximized. ATC will accomplish this by considering as wide a variety of scenarios as practical, including maintenance scenarios, when evaluating alternative transmission projects or plans.

12.6.3. Remedial Action Schemes (RAS)

Remedial action schemes (RAS) are not preferred means of mitigating system limitations but may be employed by ATC as temporary measures and are not normally considered a long-term solution. Proposal of a new RAS may require ATC executive approval via the Asset Investment Management (AIM) process prior to becoming a formal alternative proposed by ATC's System Planning.

12.7. Radial Transmission Service

ATC will evaluate the risk of serving customer load from radial facilities. Such evaluations will consider the amount of load being served, the capability of the underlying distribution

system and the amount of time that service is likely to be interrupted for the loss/failure of the radial facility.

12.8. Relaxation of Criteria

At times, it may be appropriate to consider a relaxation of ATC-specific criteria, if NERC and Regional Entity (RE) standards are still satisfied. As planning engineers perform their work, they should evaluate when it may be appropriate to allow a relaxation of ATC-specific criteria. A decision to relax ATC-specific criteria should be made very carefully considering all the issues involved (including but not limited to Electric Reliability Organization and RE requirements and FERC directives related to transmission service requirements) and then only after performing a detailed assessment of the types and levels of risks involved in the decision. Planning engineers are not permitted to relax ATC-specific criteria on their own. Instead, these situations should be identified and discussed with their manager for further evaluation. The final decision in this regard will be made by the Director of System Planning. If any decisions of this type are made, then these decisions will be documented and archived for future reference.

12.9. Steady State Voltage Stability Margin Identification

The System Operating Limit (SOL) will be identified by finding the short-term steady state post-Contingency P-V curve nose and applying the required applicable margin. This post-Contingency real power flow is related back to the pre-Contingency real power flow that occurs at the same transfer step. In practice, the post-Contingency real power flow with the required margin will usually not be equal to the flow at a discrete transfer step. In this case, the greatest transfer step with post-Contingency real power flow less than or equal to the post-Contingency real power flow with the required margin applied should be related back to the pre-Contingency real power flow. The Control Point is then defined as the pre-Contingency real power flow that is 98 percent of the SOL. Due to the margin being applied on the post-Contingency real power flow, the transfer step size can affect the SOL. Engineering judgment should be applied to determine the transfer step size.

ATC prefers the use of DSATools Voltage Security Assessment Tool (VSAT) to perform steady state voltage stability analysis.

Definitions of terms used in Planning Horizon Steady State Voltage Stability studies:

Critical bus: The bus that is most voltage-sensitive to the power transfer.
Engineering judgment may be applied when multiple buses have similar results.

Short-term steady state: The post-transient period before typical load tap changers and mechanically switched shunts can operate.

Most limiting or worst contingency: The contingency that results in the most limiting SOL.

P-V nose: The transfer point where the maximum real power interface flow occurs. Therefore, if there is no inflection point at the maximum transfer level on the P-V curve, then the last solved point will be used as the P-V curve nose.

Voltage instability: All power transfers greater than the transfer at the P-V curve nose.

Control Point: The SOL or IROL flow threshold where mitigation actions are initiated.

12.10. Series Reactor Application Project Diagram

Any project diagram that includes the addition of a series reactor should include a shunt capacitor drawn on the breaker side of the reactor and the potential need for the capacitor (to be determined by the project engineer) should be mentioned in the diagram's project notes. Including the shunt capacitor is required to reiterate to the project team that all series reactor additions need the project engineer to determine if a shunt capacitor is needed and the size of the capacitor (if needed). A shunt capacitor is usually needed on the breaker side of a series reactor to reduce the transient recovery voltage (TRV) rate-of-rise across the breaker to a level that will not compromise breaker operation.

12.11. Non-BES Generating Unit Stability

As described in Section 2.1 of ATC's Planning Criteria, generator transient stability will be demonstrated for at least one key Contingency for each applicable P1 through P7 Contingency for all BES generating units and generating units required to submit "as-built" Generating Facility modeling data according to their Interconnection Agreement or comparable data as acceptable to ATC. For all other generating units, generator transient stability will be demonstrated for at least one key P1 Contingency only. If a Non-BES generating unit without "as-built" modeling data exhibits stability concerns or disconnects during a fault simulation of a P2 through P7 Contingency, then the engineer will assess the post-event reliability of the BES. The Generator Owner may also be notified of the study results.

13. INTERCONNECTION STUDIES

The following analyses and procedures should be performed for all new or modified interconnection facilities (generation, transmission, and end-user) to the ATC system to properly assess their reliability impact on the interconnected systems. For some analyses, a formal study report may be appropriate. For other analyses, a simple statement of assumptions and rationale may be sufficient.

13.1. Types of Analysis

The analyses are to include steady state, short-circuit, and dynamic assessments that include the requirements in accordance with MISO processes.

13.2. Compliance with Applicable Requirements

Compliance with applicable requirements (i.e. applicable NERC, Regional Entity, and individual system planning criteria of the affected parties) will be achieved through interconnection studies, TYA, and MISO MTEP analysis.

13.3. Coordination with Affected Entities

The results of the analyses will be jointly evaluated and coordinated by the affected entities.

13.4. Essential Documentation

All analyses should include the evaluation assumptions, system performance, alternatives considered, and any jointly coordinated recommendations.

13.5. Flow Regulating Equipment

To ensure continued operating flexibility during unexpected system conditions, consideration of adjustments to flow regulation equipment (including, but not limited to, phase angle regulators and high voltage direct current equipment) to accommodate the interconnection of new facilities (generation and transmission) and the approval of Transmission Service Request is prohibited, except under unique circumstances, as defined by ATC. Mitigating system limitations via the adjustment of flow regulating equipment is allowed on a limited and carefully considered basis. Adjustments to flow regulation equipment could lead to conflicting objectives and is intentionally limited to cases that improve system robustness. Limiting adjustment of flow regulation equipment applies for equipment that is not primarily providing voltage support.

13.6. Specific Study Methodologies

13.6.1. Generator Interconnection Studies

1) Generator Outlet Emergency Rating Evaluation

Generation stations with only two transmission network outlets are subject to a generator outlet rating evaluation in the MISO Definitive Planning Phase System Impact Study.

For the loss of one outlet, the remaining outlet shall not be loaded above 100% of its applicable emergency rating with the following power flow assumptions:

1. Sum of any existing ERIS and requested future ERIS within the same network outlets.
 - a. Local distribution load within the same network outlets may be considered on a case by case basis.
2. 0.95 power factor based on ATC's standard power factor range for Interconnection Generating Units.

An ERIS network upgrade is required if a generator outlet does not meet the rating requirement above and there is no other identified ERIS network upgrade that could

mitigate the constraint. The ERIS network upgrade should be cost allocated proportionally to study generators connecting within the same network outlets based on the requested ERIS levels. In case of pre-existing issues, the study generators are only responsible for the portion of the outlet rating increase resulting from their interconnection requests.

- 2) ATC will use guidelines from the MISO Business Practice Manual 015 *Generation Interconnection* to calculate Distribution Factors (PTDF and LODF) to estimate the impact of several Generator Interconnection Requests on a transmission facility for cost allocation purposes.
- 3) Steady State studies will model generation following the guidelines in the MISO Business Practice Manual for Generator Interconnections.
- 4) Dynamic stability studies shall dispatch generation in the study area to ensure expected more severe operating scenarios are assessed. Generally, this will involve dispatching all generation local to the study area regardless of fuel type, load level, or merit order. Engineering judgment and potentially sensitivity analysis should be utilized to determine a severe, yet credible dispatch.
- 5) Existing generators in the study area with Interconnection Agreements allowing for higher seasonal output (e.g., combustion turbines with increased output capability at colder ambient temperatures) shall be modeled at that output level during dynamic stability studies. New Interconnection Requests with higher seasonal output levels will be analyzed at the higher output if the Interconnection Customer elects the additional capacity in the MISO Generator Interconnection Process.

13.7. Other ATC Interconnection Studies and Considerations

Devices utilizing power electronic conversion equipment may require special studies. Alternatively, the siting or modification of traditional generation or transmission devices near existing devices with power electronic conversion equipment may also require special studies.

The specific types of studies of concern may include, but are not limited to, the following:

- 1) Studies required in “weak grid” conditions
 - a. Control interactions between multiple nearby power electronic or IBRs (e.g., type 3 or 4 wind machines, solar PV, HVDC, STATCOM, and SVC).
 - b. Sub-synchronous studies near IBRs, HVDC, SVCs, STATCOMs, etc. For example, Sub-Synchronous Torsional Interaction (SSTI), Sub-Synchronous Resonance (SSR), Sub-Synchronous Oscillations (SSO), and Sub-Synchronous Control Interaction (SSCI).

- c. Fault ride through performance verification (e.g. to support FERC order 828, PRC-024-2, etc.). This could be especially applicable to IBRs which may have unusual responses during and after fault conditions.
 - d. Other “weak grid” related studies for devices connecting to an area with low short circuit strength (voltage regulation, other control or protection system tuning, etc.)
- 2) Control interaction studies required for non-weak grid conditions (e.g. power electronic/converter devices near to each other, etc.)
 - 3) Power quality around generators or other devices utilizing power electronic converters; especially those with IGBTs. This includes harmonics, interharmonics, and other applicable power quality topics. This may apply to power electronic or IBRs.
 - 4) Confirmation that an IBR EMT model is stable in a system case to ensure the IBR EMT model will not impede any future EMT studies in the area.

Screening level studies and engineering judgment will be used, as appropriate, to determine the depth and breadth of detailed analysis required for the concerns and topics outlined above.

13.8. Generator Material Modification Study Review Prior to Commercial Operation

ATC requires generator interconnection customers to follow the instructions described in ATC Area Generator Material Modification Study Review Template posted on ATC’s website (<https://www.atcllc.com/customer-engagement/connecting-to-the-grid>) when submitting a generator material modification study to MISO prior to commercial operation.

14. UNDER-FREQUENCY LOAD SHEDDING (UFLS)

The UFLS Program performance assessments include, but are not limited to the following practices:

- 1) Are performed at least once every five years for each identified island
- 2) Are based on the most recent UFLS Program data that is collected annually from the Distribution Providers connected to the ATC system
- 3) Are based on the most recent under-frequency and over-frequency settings provided by Generation Owners connected to the ATC system, otherwise the setting limits given in the NERC PRC-025 Reliability Standard are assumed to apply
- 4) Consider generation-load imbalance scenarios up to 25 percent within the identified island [per the NERC PRC-006 Reliability Standard]
- 5) Use the Equivalent Inertia method for the frequency performance evaluation

- 6) Use the assumptions of aggregate inertia range of 3.3 to 4.7, generator governor droop range from 12 to 18 percent, and load damping range of 1.0 to 2.0 percent in the Equivalent Inertia simulations
- 7) Use the PSSE Dynamic Module method for the volts per hertz evaluation
- 8) Use complex load modeling in the PSSE Dynamic Module simulations.

The Capacitor Bank Coordination assessments include, but are not limited to the following practices:

- 1) Are performed at least once every five years for each identified island.
- 2) Are based on the most recent UFLS Program data that is collected annually from the Distribution Providers connected to the ATC system.
- 3) Are based on the most recent under-frequency and over-frequency settings provided by Generation Owners connected to the ATC system, otherwise the setting limits given in the NERC PRC-025 Reliability Standard are assumed to apply.
- 4) Are based on the most recent over-voltage and under-frequency settings of shunt reactive power devices that are requested from ATC System Protection.
- 5) Consider generation-load imbalance scenarios up to 25 percent within the identified island [per the NERC PRC-006 Reliability Standard].
- 6) Use the PSSE Dynamic Module method for the voltage response evaluation.
- 7) Use complex load modeling in the PSSE Dynamic Module simulations.

15. REFERENCES

NERC Dynamic Load Modeling Technical Reference Document, December 2016

16. ADMINISTRATION

16.1. Review

This document may be revised from time to time in response to changes in industry standards, new system conditions, new technologies and new operating procedures, as appropriate. Annually the need for a full review will be evaluated.

16.2. Retention

The previous version of this document will be retained for at least five years after it becomes retired.

17. REVISION HISTORY

Revision	Author(s)	Manager(s)	V.P.(s)/ Director(s)	Summary of Changes
1	Connie Lunde, et alia	David Smith, Paul Walter	Ron Snead	Primary – split Criteria and Practices into separate documents, moved Operations fault assumptions text; Details – Summary of Planning Criteria V14 and Practices V1 Revisions document.
2	Shane Ehster, et alia	David Smith, Paul Walter	Ron Snead	Primary – added sections for dynamic load modeling and UFLS analysis, added hydro generation dispatch methodology and SPS language in the Operating Considerations section, moved Variations on ATC Planning Criteria section to Planning Criteria, added language regarding the analysis of Category D stability simulations, removed specific references to internal ATC guides and procedures.
3	Curtis Roe et alia	David Smith, Paul Walter	Ron Snead	Revised NERC references to TPL-001-4, revised annual review requirement, and added generator interconnection specifics.
4	Curtis Roe et alia	David Smith, Paul Walter	Andy Dolan	Added justification in the TRM section, Flow Regulating Equipment section, and wind generation power factor consideration in the G-T section.
5	Curtis Roe et alia	David Smith, Paul Walter	Andy Dolan	Minor revision to Flow Regulating Equipment section and various NERC standard updates (MOD-010, MOD-012, & MOD-016 with MOD-032; and MOD-024 with MOD-025).
6	Curtis Roe et alia	David Smith, Paul Walter	Andy Dolan	Revised Section 1.6 Facility Condition Methodology, revised section 9.7 Minimum Load, and added Section 13.7 Other ATC Interconnection Studies and Considerations.
7	Curtis Roe et alia	David Smith, Paul Walter	Andy Dolan	Modified Sections 13.1 and 13.2 to include MISO MTEP analysis.
7.1	Curtis Roe et alia	David Smith, Paul Walter	Andy Dolan	Modified Sections 12.2 to remove reference to TPL Extreme Event analysis.
7.2	Curtis Roe	Paul Walter	Andy Dolan	Revised power factor limit (new limit 0.95 lagging).
7.3	Chengyue Guo et alia	Paul Walter	Andy Dolan	Removed 5% TRM requirement for MISO Generation Interconnection Studies.
20	Michael Marz, David Smith	Paul Walter	Andy Dolan	Added Section 12.10 requiring Series Reactor Shunt Capacitor Additions on Project Diagrams. Jumped from version 7.3 to version 20, to align with TYA year.
20.1	Joel Berry	Adam Manty	Andy Dolan	Revised Section 12.9. to describe the updated Steady State Voltage Stability Margin definition.
21	David Smith et alia	Adam Manty, Paul Walter, Robert Morton, Dale Burmester	Andy Dolan	Removed old footnote 1 related to emergency thermal ratings, especially in section 4.1. Identify to which generators stability criteria applies, particularly section 12.11.
21.1	Chengyue Guo et alia	Paul Walter	Andy Dolan	Updated substation terminal equipment rating design methodology in Section 12.3
22	Jamal Khudai et alia	Paul Walter	Andy Dolan	Updated Wind Generation Dispatch Methodology section 5.2.3 and Solar Generation Dispatch Methodology section 5.2.4 Updated Non-BES Generating Unit Stability section 12.11 Updated Generator Interconnection Studies section 13.6.1
22.1	Jamal Khudai, Joel Berry,	Paul Walter	Tom Dagenais	Update Dynamic Load Modeling Section 5.4 Update Multiple Contingency Planning Section 12.2

Caution: Any hard copy reproductions of this document should be verified against the on-line system for current revisions.

	Bob Krueger, et alia			Update Other ATC Interconnection Studies and Considerations Section 13.7
22.2	Chengyue Guo et alia	Paul Walter	Tom Dagenais	Included a generator outlet emergency rating requirement in Section 13.6.1 and included a requirement of interconnection customers using ATC Area Generator Material Modification Study Review Template when submitting a generator material modification study in Section 13.8.
22.3	Damien Sommer, Chengyue Guo et alia	Paul Walter	Tom Dagenais	Included a requirement to confirm IBR EMT model performance in a system case in Section 13.7